

# East Cleveland: Furniture, Theatre, Opera. Ideas for a curriculum



Tony Shaw  
Senior Lecturer in Production Design for Stage &  
Screen  
The Northern School of Art

## Recommended citation:

Shaw, T. (2023) East Cleveland: Furniture, Theatre, Opera. Ideas for a curriculum. PAD| Perspectives in Art and Design. Edition 5. The Northern School of Art Research & Scholarly Activity Conference. July 2023





Research Photographs & measurements by MA Student Angela List Evans: The Attic at Ormesby Hall

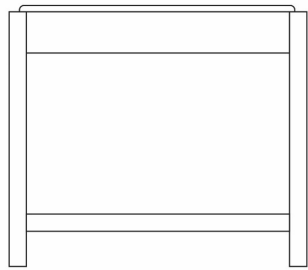
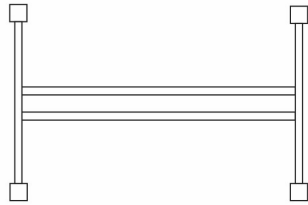
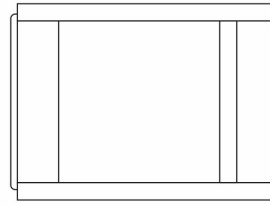
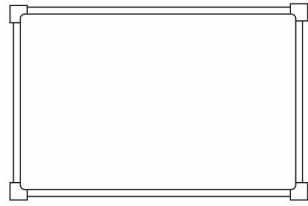

Boosbeck Industries Models  
1 Model Stool  
Full Scale

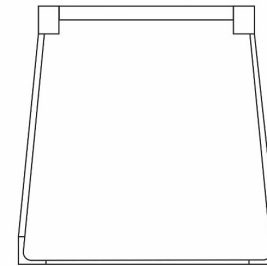
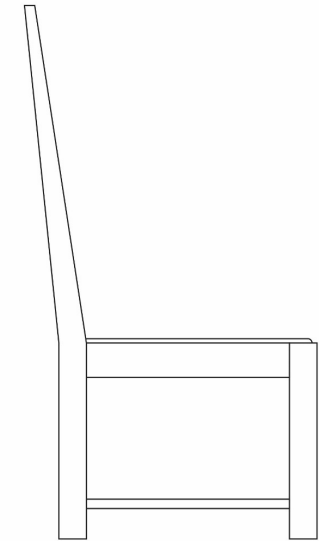
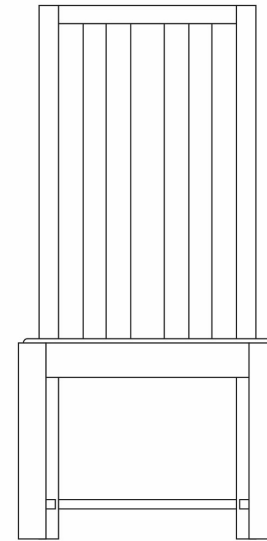

Boosbeck Industries Models  
1 Model Chair  
Full Scale

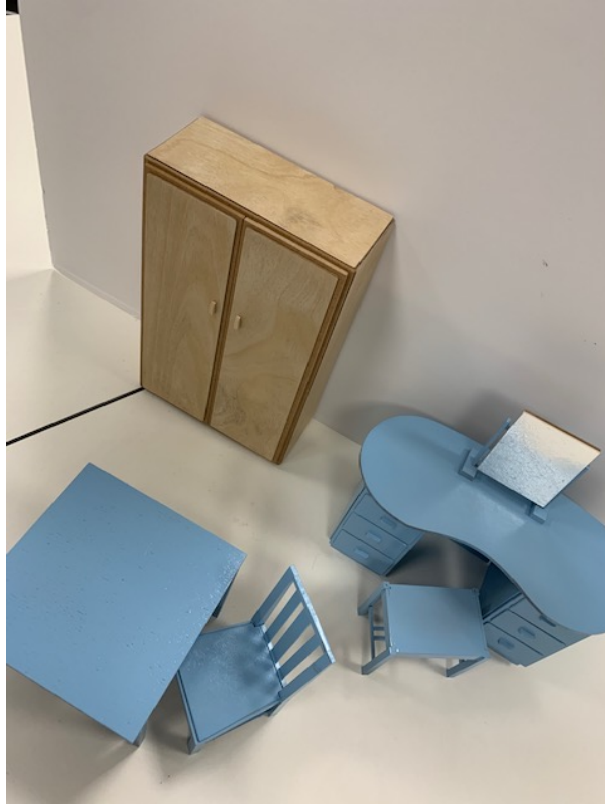

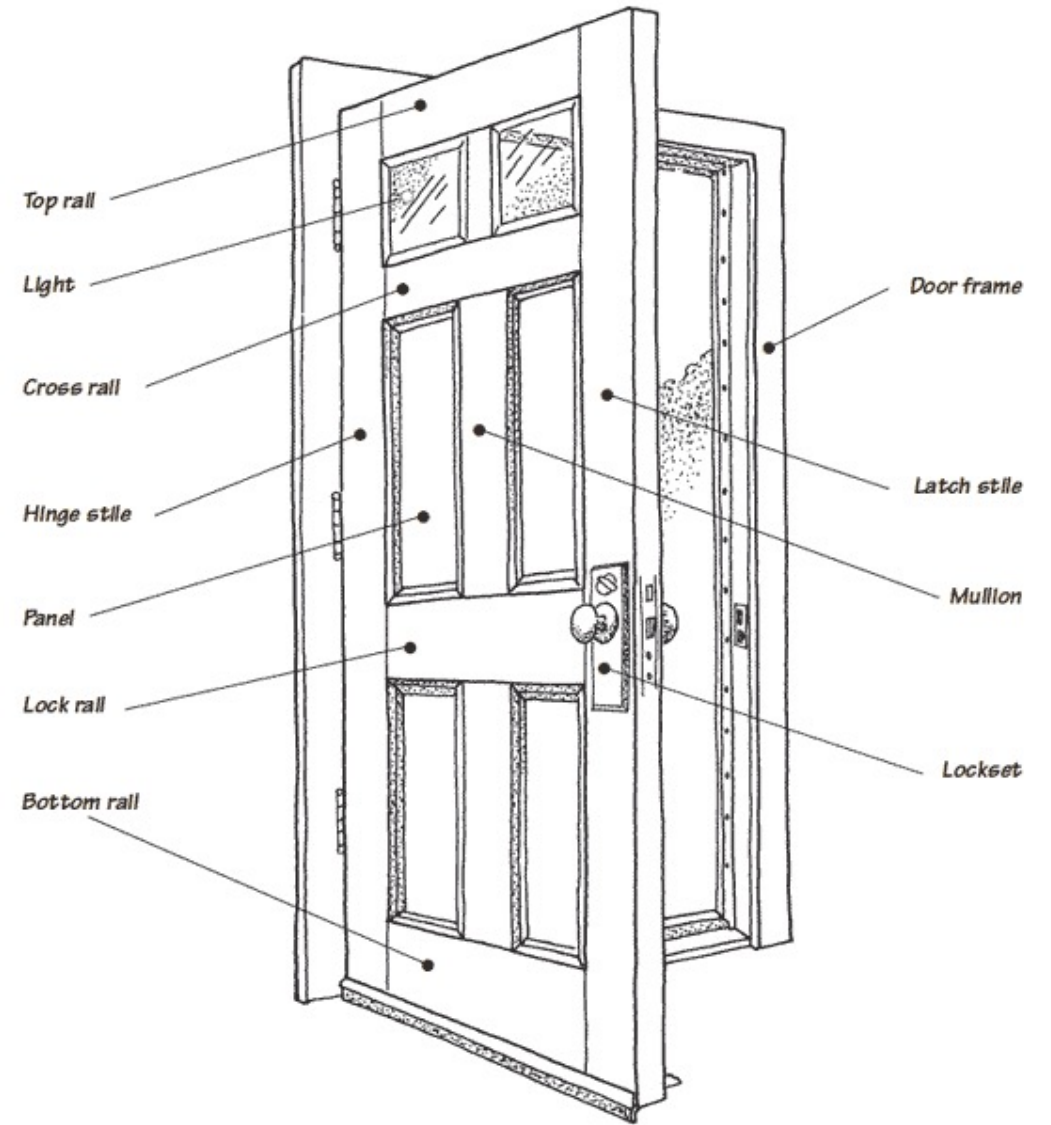
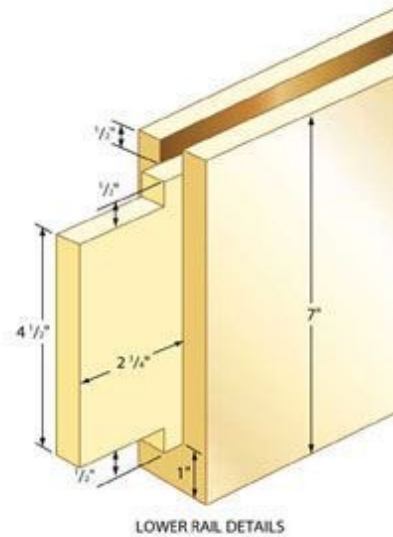
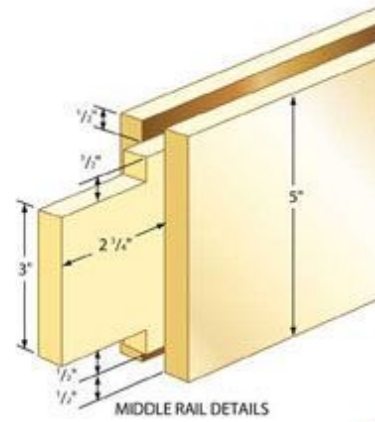
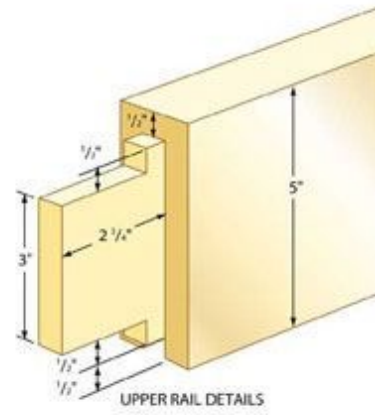
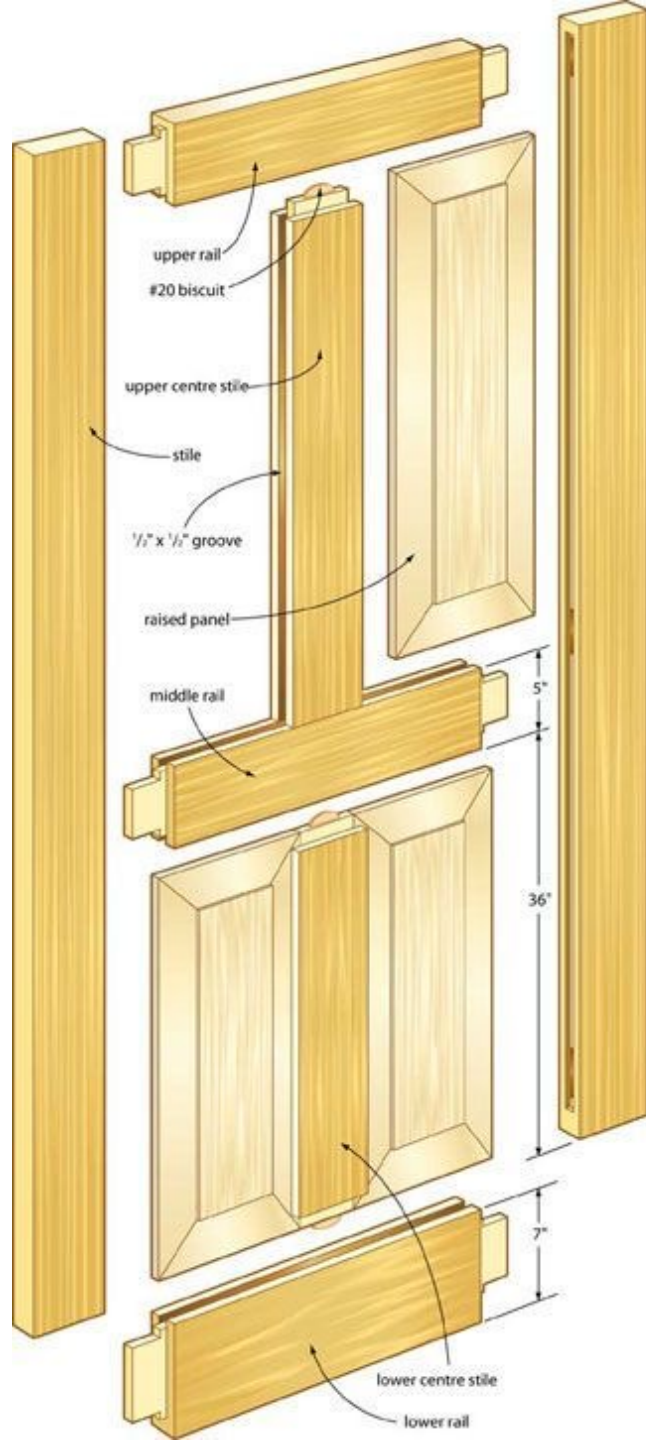

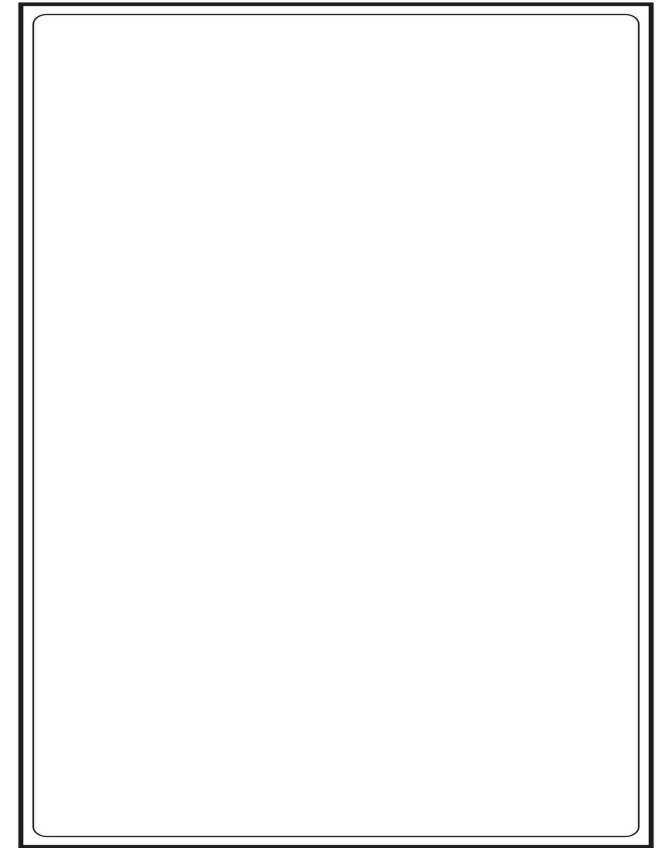
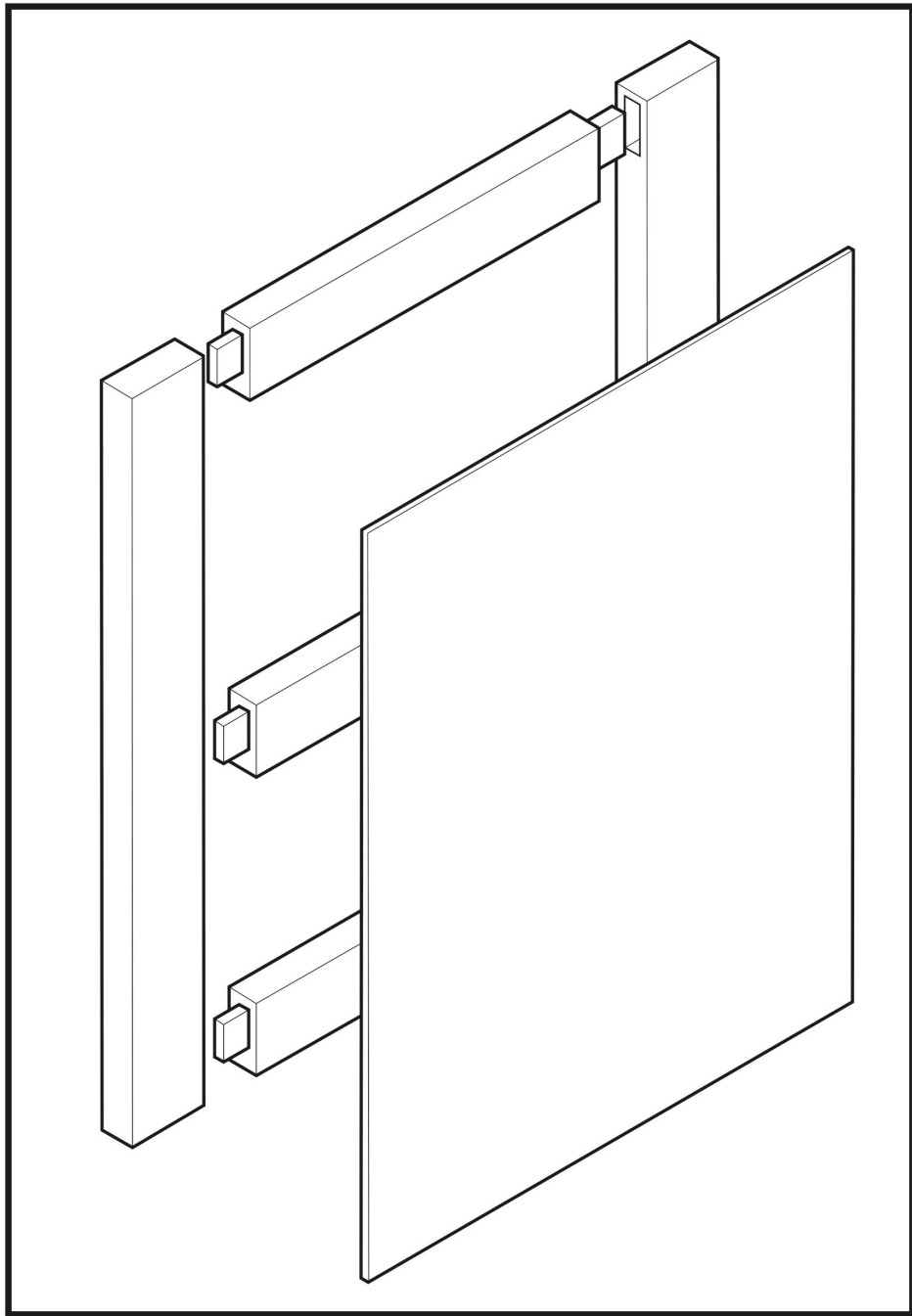

Simplified cabinet door construction.  
Just rails and stiles.



1945 Utility Furniture in a setting





## Utility Furniture 1941 to 1947

Top Left: Sideboard 1942 to 1947

Right: Oak Dressing Table by the Utility Design Panel 1943

*Both Manufactured by Heal & Son*





Trendy Cutting edge furniture 1930s



1940s Utility Furniture



1960s Cheap Mass Produced



My Fair Lady 1964: Warner Brothers. The Set for Mrs Higgins House reeks of Macintosh a direct contrast to her son's Victorian eclectic home. Design by Gene Allen (Not Cecil Beaton who did the costume)

<https://hookedonhouses.net/2019/05/22/my-fair-lady-movie-sets/>

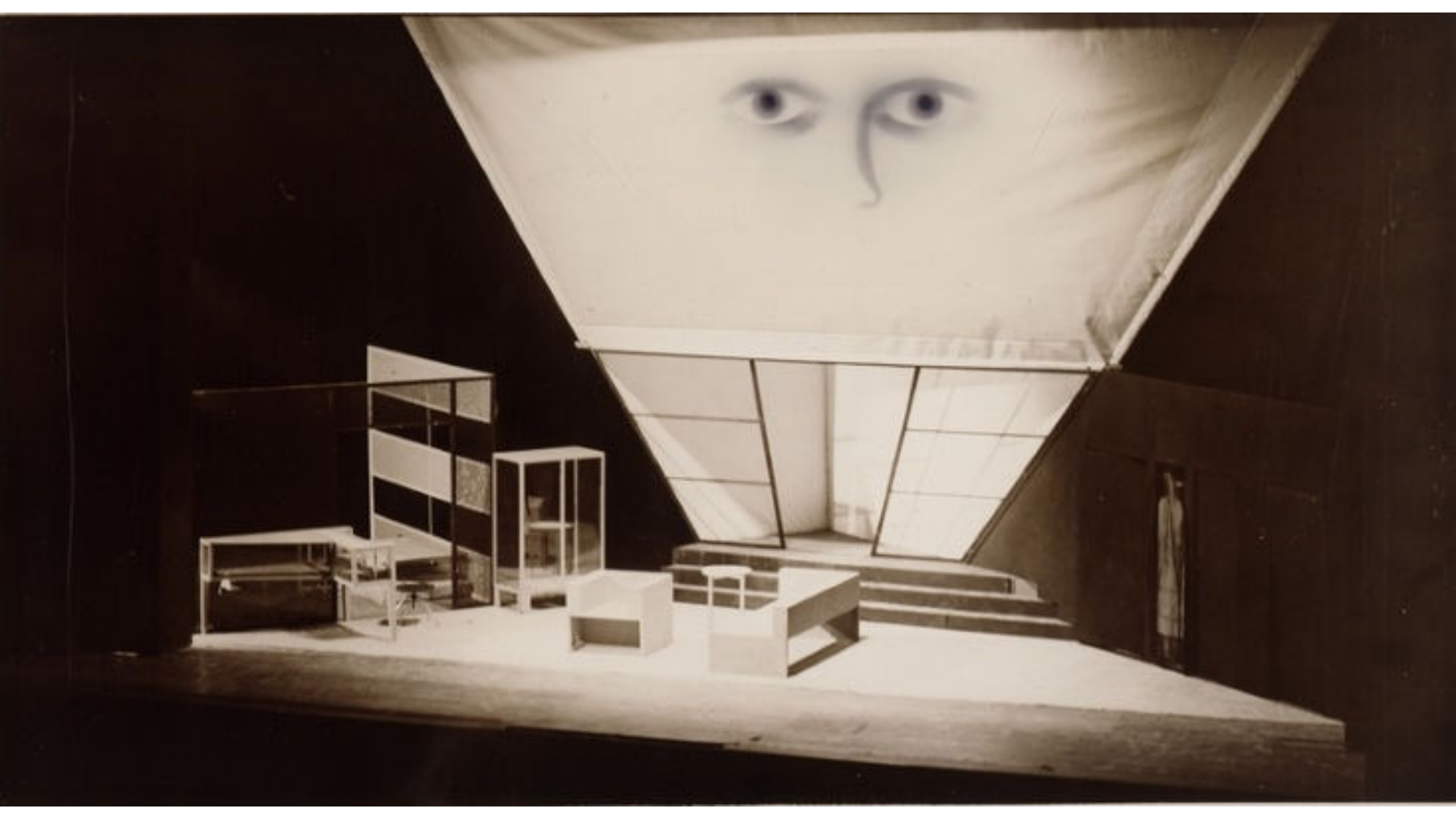

**PAD**

Perspectives in Art and Design